

PROBLEM 1.64**GIVEN:** A flywheel used for energy storage.

Clearly indicate the problem number

ALL problem solutions **MUST** have an accompanying visualization. This can be a hand-sketch or a figure directly from the text (all text figures are provided on BbLearn).

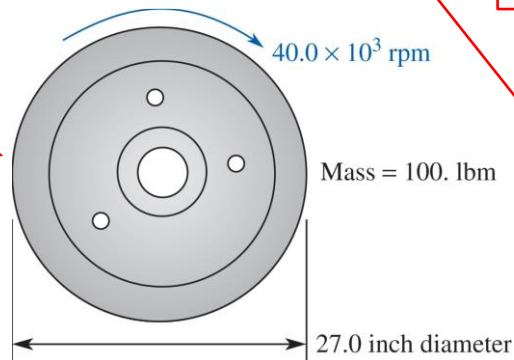

ALL problems must have a **GIVEN** statement. Indicate the information given in the problem statement. Some of the given information can be displayed in an accompanying drawing

FIND: (a) the rotational kinetic energy stored in the flywheel
(b) the energy storage capacity of the flywheel (W-hr/lbm)

ALL problems must have a **FIND** statement. Indicate the information required in the problem solution

SOLUTION: (a) The rotational kinetic energy of the flywheel is,

$$(\text{KE})_{rot} = \frac{I\omega^2}{2g_c}$$

NEATLY describe your path to the **SOLUTION** of the problem. Do not be afraid to use text to explain what you are doing!

The mass moment of inertia of a solid circular cylinder rotating about its center can be found in Table 1.7,

$$I = \frac{mr^2}{2} = \left(\frac{1}{2}\right)(100 \text{ lbm})\left(\frac{27 \text{ in}}{2}\right)^2 \left(\frac{1 \text{ ft}}{12 \text{ in}}\right)^2 = 63.28 \text{ ft}^2\text{-lbm}$$

Reference Tables and Graphs that you have used to solve the problem.

Then,

$$(\text{KE})_{rot} = \frac{(63.28 \text{ ft}^2\text{-lbm})\left(40,000 \frac{\text{rev}}{\text{min}}\right)^2 \left(\frac{2\pi \text{ rad}}{\text{rev}}\right)^2 \left(\frac{\text{min}}{60 \text{ s}}\right)^2}{2\left(32.174 \frac{\text{lbm}\text{-ft}}{\text{lbf}\text{-s}^2}\right)} = \underline{\underline{1.73 \times 10^7 \text{ ft}\text{-lbf}}}$$

Converting to W-hr (part (b) is in terms of these units!),

$$(\text{KE})_{rot} = (1.73 \times 10^7 \text{ ft}\text{-lbf}) \left(\frac{1055.0 \text{ J}}{778.16 \text{ ft}\text{-lbf}}\right) \left(\frac{\text{hr}}{3600 \text{ s}}\right) \left(\frac{\text{W}\text{-s}}{\text{J}}\right) = \underline{\underline{6498 \text{ W}\text{-hr}}}$$

(b) The energy storage capacity of the flywheel is the energy stored per unit mass,

$$ke_{rot} = \frac{(\text{KE})_{rot}}{m} = \frac{6498 \text{ W}\text{-hr}}{100 \text{ lbm}} = \underline{\underline{6.498 \frac{\text{W}\text{-hr}}{\text{lbm}}}}$$

EVERY calculation **MUST** be accompanied with a **UNIT ANALYSIS**. This is **NECESSARY**. You **WILL** lose points if you do not conduct a unit analysis, even if you have the right answer.

REFLECTION:

- This is a fairly large flywheel spinning at a high rotational speed. The combination of these allows for a substantial amount of energy storage. This, however, is not a 'free' source of energy because energy had to be used to make the flywheel spin in the first place.
- This problem introduces a new energy unit; the W-hr. When we purchase energy from the electrical utility, we purchase kW-hr (kWh). W is a power unit (energy/time). Therefore multiplying by time results in an energy value.



Every problem should end with a REFLECTION. This is a brief statement (or statements) that indicate what you learned by solving this problem. Your reflections must be professional (no wise remarks) and meaningful. If this section is not included in your problem, you will lose points. If you write a silly reflection that is not addressing fundamental issues related to the problem, you will lose points. Sometimes, a proper reflection can end with a question!